



Pilous

Železná 9, 619 00 Brno, Czech Republic

Tel.: +420 543 25 20 10

e-mail: wood@pilous.cz, www.pilous.cz

CTR 550 GX



3340 x 27-35 x 0,9 mm

Max. log diameter	550 mm
Max. opening between blade guides	500 mm
Max. elevation of blade	465 mm
Min. log height	20 mm
Max. depth of cut	200 mm
Max. log length (standard model)	3,6 m
Length track section	2,25 m
Min. log length	0,9 m
Saw blade motor	8,7 kW
Saw blade	3340 x 27-35 x 0,9 mm
Weight (standard model)	310 kg
Weight (track section)	54 kg

DESCRIPTION

Feed into the cut and back - hand-operated

Arm height adjustment - manual

Control panel - on a mobile bridge

Log handling - manual

In contrast to the standard version the sawmill is equipped with a professional Honda 8.7 kW (11 HP) petrol engine. Sufficient engine power allows trouble-free processing of logs of large diameters in all applications without the possibility of using an electric motor. Overall low weight allows easier transport of the machine. Due to higher weight and vibrations of petrol engine the construction of travelling bridge and sawmill arm is completely reinforced. The smallest machine in the offer. It is designed primarily for cutting smaller volumes of lumber. Ideal solution for family farms or small sawmilling companies. Very simple hand feed into the cut and back. The control panel is placed on a mobile bridge of the sawmill arm. Thanks to that the operator has closer access to the workpiece when cutting. Height is adjusted using a hand crank with adjustable scale.

The solidly mounted drive wheel is driven via a V-belt by a professional Honda petrol engine. Mechanical clutch lever enables an easy start of the engine and removal of the engine from the saw blade when the cut had finished.

The tensioning wheel system moves in a cast iron guide, which guarantees long service life and precision adjustment even with long-term use of the machine. The arm is fitted with aluminium running wheels with precise anti-vibration balancing. The circumference of the wheel has a recessed groove in which a replaceable rubber-textile V-belt is fitted, which forms the contact surface between the wheel and the saw blade. The stability of the machine is based on solid steel travel sections, which ensure optimum guidance of the sawmill bridge. The travel sections are fitted with tilting angle bars and log clamps/cam dogs.

The samill CTR 550 GX uses standard sawmill blades 27-35 x 0.9 mm as with the fully professional models.

The CTR model series represents the latest trends in log-cutting sawmill design, with special emphasis on maximum accuracy and long service life at minimum cost. The machines are designed in an original modular way, which allows easy replacement or adjustment of all main technical nodes and their individual parts. This significantly reduces maintenance costs in the long-term use of the machine and also reduces service times, thus reducing production downtime.

All pictures shown are for illustration purpose only. Actual product may vary due to product enhancement.

PHOTOGALLERY

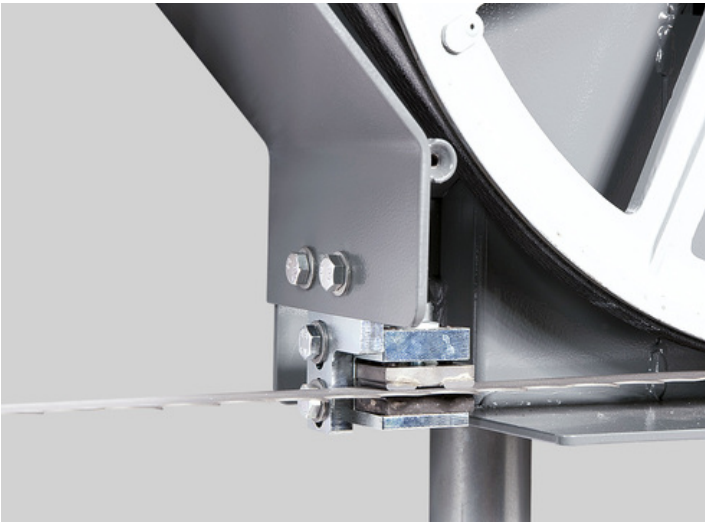
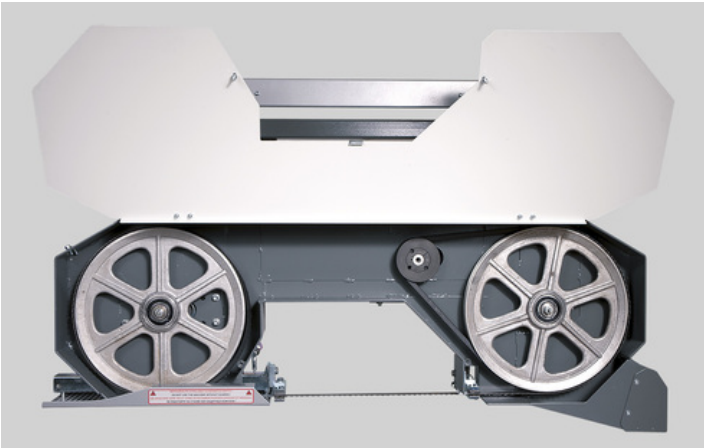
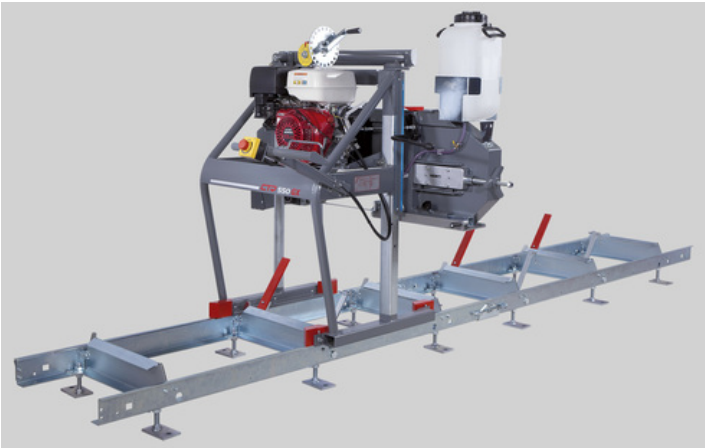
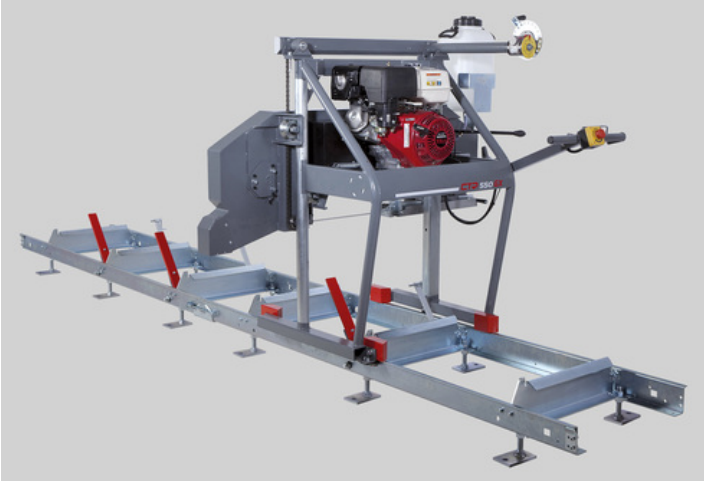

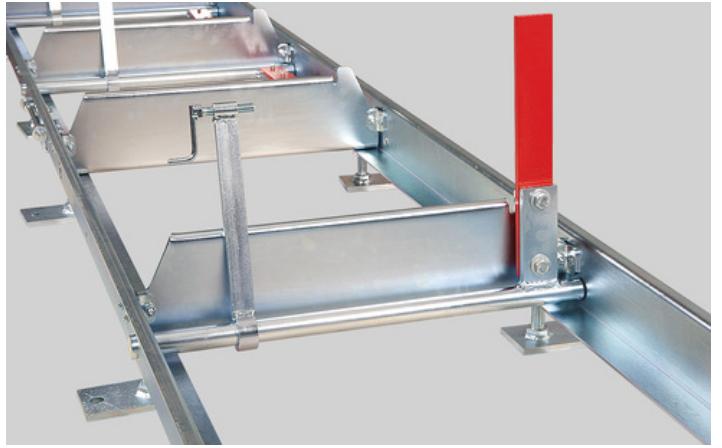
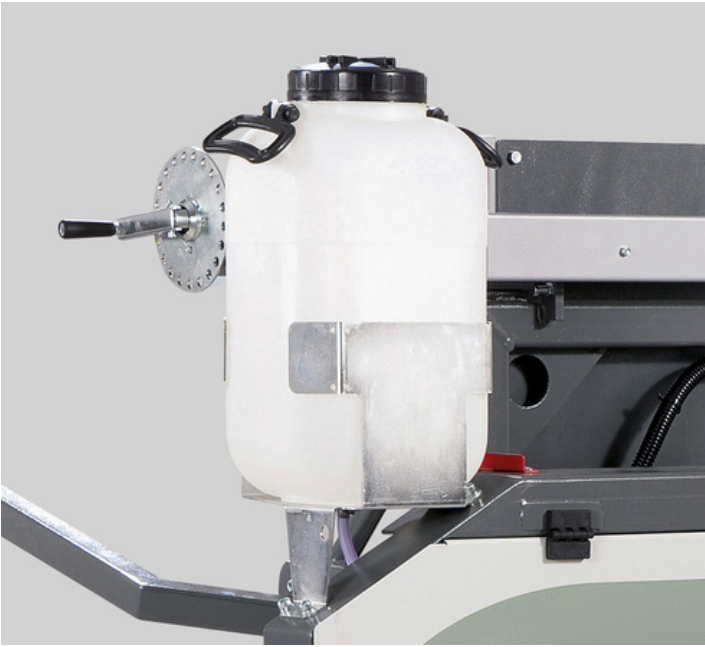

ACCESSORIES

ACCESSORIES – SPECIAL ACCESSORIES



2,25 m

**Extending section
2,25m**

Extending section 2,25 m

Include: 3x Cross beams, 1x Tilting angle bar, 1x Clamp
Variable points: 1x Tilting angle bar, 1x Clamp



**Saw blade tension
indicator**

Saw blade tension indicator

Ensures accurate tensioning of the saw blade to a required value according to the pressure gauge and its control during the use of the machine. Optimum tensioning of the saw blade is essential for its service life and cutting accuracy.



Cant hook

Cant hook

Serves as help with manipulation with logs on machine frame.

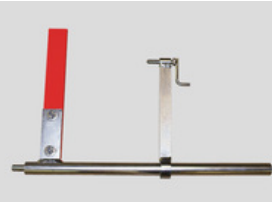

**Clamp with tilting
angle bar**

Clamp with tilting angle bar

Additional clamping kit. It consists of the clamp and a tilting angle bar.



Additional clamp

Additional clamp



Cam dog

Cam dog

For fast and easy squared lumber clamping.



Grease Gun

Grease Gun

For regular maintenance of the machine according to the lubrication plan. Metal grease gun for 400g tubes. Equipped with a flexible pressure hose.



**Synthetic Grease LV
2-3**

Synthetic Grease LV 2-3

400g tube for the grease gun.

ACCESSORIES – CONSUMABLE PARTS

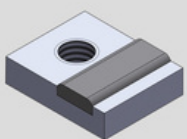

**Hard-metal Plate 20
x 0.9 mm**

Hard-metal plate 20 x 0.9 mm

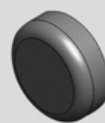

**Hard-metal Plate 9 x
6 mm**

Hard-metal plate 9 x 6 mm



**Running wheel wedge belt
17x1420 Li
Wheel wedge belt 17x1220 Li**

**Running Wheel
Wedge Belt SPB
17x1420 Li Wheel
Wedge Belt 17x1220
Li**

MAXWOOD

- The original sawmill blades PILOUS MAXwood are available in a variety of types which enables you to process any kind of wood.
- The wide product range not only offers more affordable sawmill blades for low-volume cutting, but includes also sawmill blades for fully professional cutting and utmost performance.
- The foundation of all sawmill blades are top-quality German materials and precise workmanship. The quality of the sawmill blades is carefully monitored. All sawmill blades correspond to the strict ISO 9001 norm.
- We have added to our portfolio also an original Munkfors sawmill blade made by the world's leading manufacturer Uddeholm from Sweden.
- Pilous sawmill blades are used in dozens of countries around the world. Any wood you cut, the company Pilous will recommend you a sawmill blade that will fit your needs.

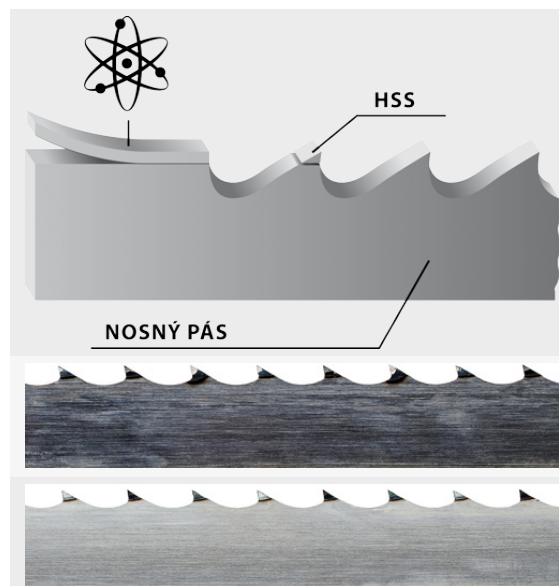

BiMetal

Sawmill blade with tool steel teeth - completely eliminates the need to sharpen the sawmill blade as well as frequent blade replacement. Use: soft, hard to extremely hard wood.

HSS

Bearing blade

Stellite

Sawmill blade with teeth made of Stellite. Tooth setting is completely unnecessary. Use: soft, hard to extremely hard wood.

Carbon spring steel

The most common sawmill blade for optimum price/performance ratio. Use: soft and hard wood.



Be careful when unpacking welded sawmill blades. They are in a shipping container in tensioned condition. Remove the sawmill blade cover only after fitting it onto the machine.

